



High-end Power Semiconductor Manufacturer

## KP300A 7000V-7500V Phase Control Thyristor

- High power cycling capability
- Low on-state and switching losses
- Designed for traction and industrial applications



Mean on-state current	$I_{TAV}$	300 A		
Repetitive peak off-state voltage	$V_{DRM}$	7000 - 7500 V		
Repetitive peak reverse voltage	$V_{RRM}$			
Turn-off time	$t_q$	800 $\mu$ s		
$V_{DRM}, V_{RRM}, V$	7000	7200	7400	7500
Voltage code	70	72	74	75
$T_j, ^\circ\text{C}$	-40 - 125			

### MAXIMUM ALLOWABLE RATINGS

Symbols and parameters		Units	Values	Test conditions	
<b>ON-STATE</b>					
$I_{TAV}$	Mean on-state current	A	300	$T_c=70\text{ }^\circ\text{C}$ ; 180° half-sine wave;	
$I_{TRMS}$	RMS on-state current	A	471	$T_c=70\text{ }^\circ\text{C}$	
$I_{TSM}$	Surge on-state current	kA	4.0	$T_j=T_{j\text{ max}}$	180° half-sine wave; ( $t_p=10\text{ ms}$ ); $V_R=0\text{ V}$ ;
$I^2t$	Safety factor	$\text{A}^2\text{s}\cdot 10^4$	8		180° sine wave; ( $t_p=10\text{ ms}$ );
<b>BLOCKING</b>					
$V_{DRM}, V_{RRM}$	Repetitive peak off-state and Repetitive peak reverse voltages	V	7000-7500	$T_{j\text{ min}} < T_j < T_{j\text{ max}}$ ; 180° half-sine wave; 50 Hz; Gate open	
$V_{DSM}, V_{RSM}$	Non-repetitive peak off-state and Non-repetitive peak reverse voltages	V	7500-8000	$T_{vj} = 25, 125\text{ }^\circ\text{C}$ ; $I_{DRM}, I_{RRM} \leq 150\text{ mA}$ ; $V_{DM} = V_{DRM}$ ; $V_{RM} = V_{RRM}$ ; $t_p = 10\text{ ms}$ ; Gate open	

<b>TRIGGERING</b>				
$I_{FGM}$	Peak forward gate current	A	4	
$V_{RGM}$	Peak reverse gate voltage	V	5	
$P_G$	Gate power dissipation	W	20	
<b>SWITCHING</b>				
$(di_T/dt)_{crit}$	Critical rate of rise of on-state current non-repetitive	A/ $\mu$ s	100	$T_{vj} = 125\text{ }^\circ\text{C}; V_{DM} = 0.67 V_{DRM};$ $f = 50\text{ Hz}; I_{TM} = 500\text{ A};$ $I_{FG} = 2\text{ A}; t_r = 0.5\text{ }\mu\text{s}$
<b>THERMAL</b>				
$T_{stg}$	Storage temperature	$^\circ\text{C}$	-40-140	
$T_j$	Operating junction temperature	$^\circ\text{C}$	-40-125	
<b>MECHANICAL</b>				
F	Mounting force	kN	15.0	

## CHARACTERISTICS

Symbols and parameters		Units	Values	Conditions
<b>ON-STATE</b>				
$V_{TM}$	Peak on-state voltage, max	V	2.90	$T_j = 125\text{ }^\circ\text{C}; I_{TM} = 500\text{ A}$
$V_{T(TO)}$	On-state threshold voltage, max	V	1.45	$T_j = T_{j\text{ max}}$
$r_T$	On-state slope resistance, max	m $\Omega$	2.900	
$I_L$	Latching current, max	mA	1000	$T_j = 25\text{ }^\circ\text{C}$
$I_H$	Holding current, max	mA	200	$T_j = 25\text{ }^\circ\text{C}$
<b>BLOCKING</b>				
$I_{DRM}, I_{RRM}$	Repetitive peak off-state and Repetitive peak reverse currents, max	mA	150	$T_j = 25\text{ }^\circ\text{C}, 125\text{ }^\circ\text{C};$ $V_{DRM}/V_{RRM};$ Gate open
$(dv_D/dt)_{crit}$	Critical rate of rise of off-state voltage <sup>1)</sup> , min	V/ $\mu$ s	2000	$T_j = T_{j\text{ max}};$ $V_D = 0.67 \cdot V_{DRM};$ Gate open
<b>TRIGGERING</b>				
$V_{GT}$	Gate trigger direct voltage, max	V	3.00	$T_j = 25\text{ }^\circ\text{C}$
$I_{GT}$	Gate trigger direct current, max	mA	300	$T_j = 25\text{ }^\circ\text{C}$
$V_{GD}$	Gate non-trigger direct voltage, min	V	0.30	$T_j = T_{j\text{ max}};$ $V_D = 0.4 \cdot V_{DRM};$
<b>SWITCHING</b>				
$t_q$	Turn-off time <sup>2)</sup> , max	$\mu$ s	800	$T_{vj} = 125\text{ }^\circ\text{C}; V_{DM} = 0.67 V_{DRM};$ $I_T = 1000\text{ A}; dv/dt = 20\text{ V}/\mu\text{s};$ $V_R = 200\text{ V}; -di/dt = 1.5\text{ A}/\mu\text{s}$
$Q_{rr}$	Total recovered charge, max	$\mu$ C	2000	$T_{vj} = 125\text{ }^\circ\text{C}; -di/dt = 1.5\text{ A}/\mu\text{s};$ $I_T = 1000\text{ A}; V_R = 200\text{ V}$
$I_{rrM}$	Peak reverse recovery current, max	mA	150	$T_{vj} = 25\text{ }^\circ\text{C}, 125\text{ }^\circ\text{C}; V_{DRM}/V_{RRM}$ Gate open

THERMAL				
$R_{thjc}$	Thermal resistance, junction to case, max	$^{\circ}C/W$	0.045	Direct current
$R_{thck}$	Thermal resistance, case to heatsink, max	$^{\circ}C/W$	0.008	Direct current
MECHANICAL				
w	Weight, typ	g	350	

**OVERALL DIMENSIONS**

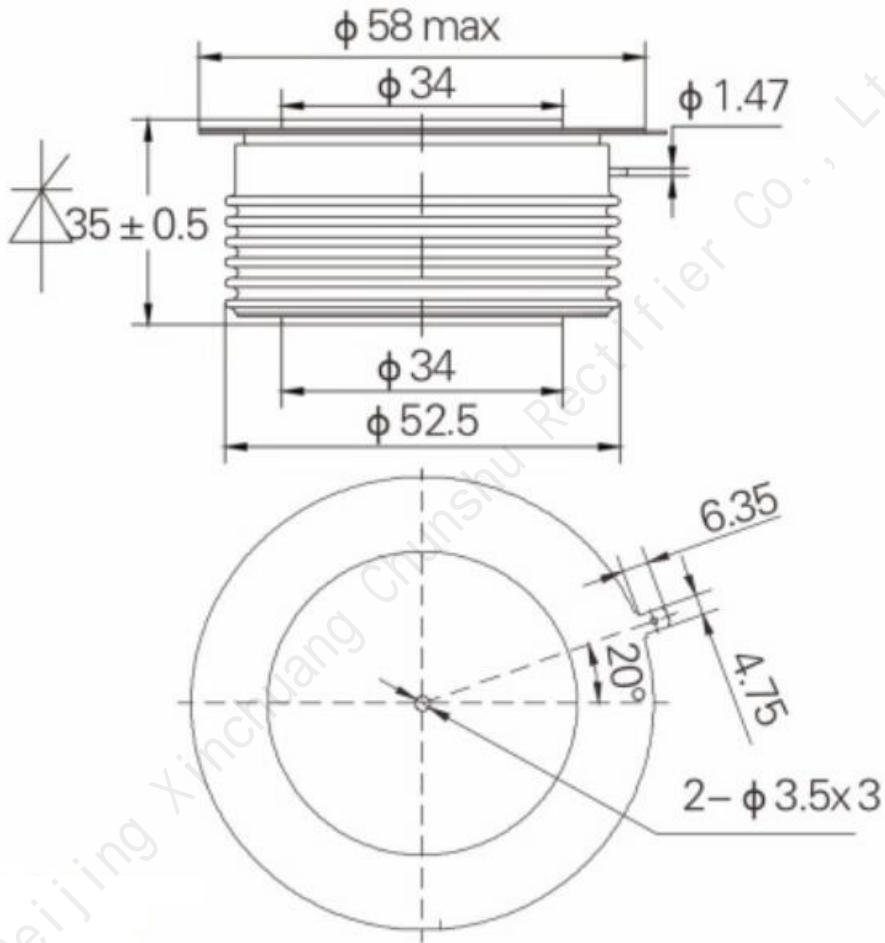

KT40DT

All dimensions in millimeters



图1. 通态伏安特性曲线



图2. 瞬态热阻抗曲线

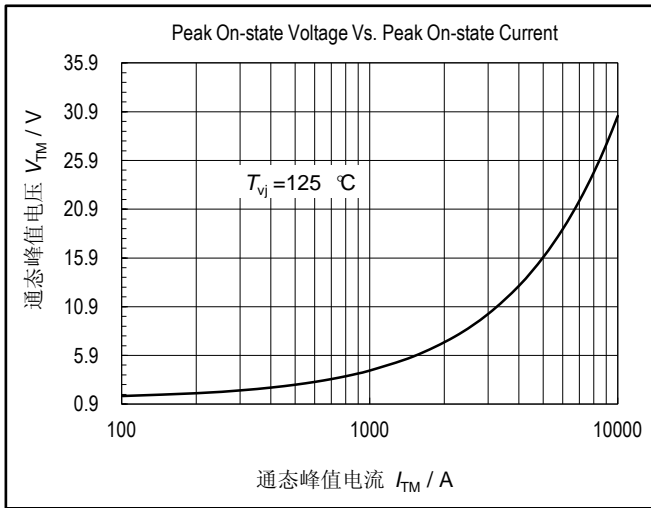

图3. 最大功耗与通态平均电流的关系曲线

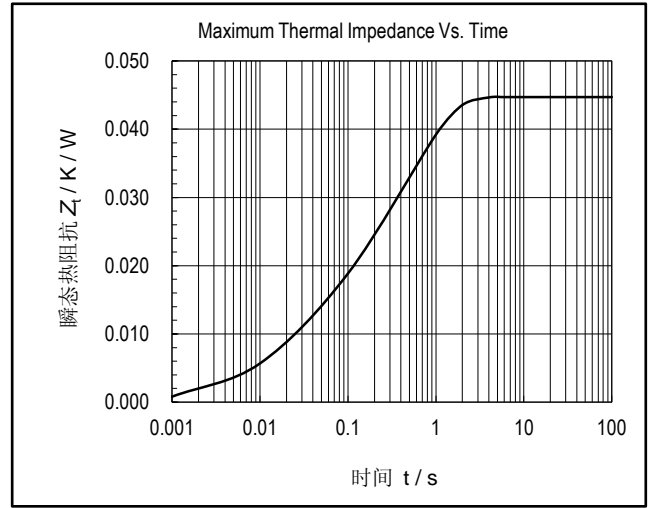

图4. 管壳温度与通态平均电流的关系曲线

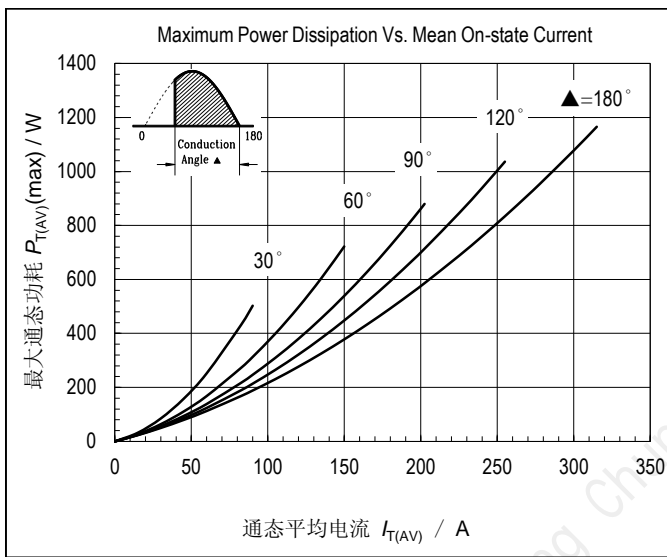

图5. 最大通态功耗与通态平均电流的关系曲线

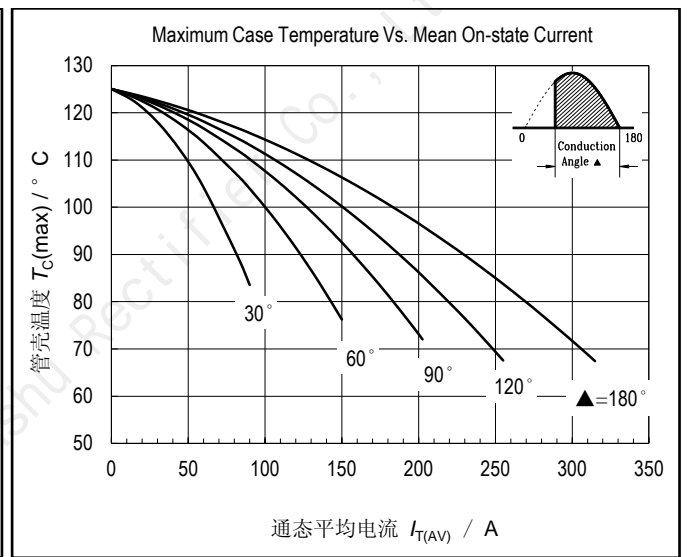

图6. 管壳温度与通态平均电流的关系曲线

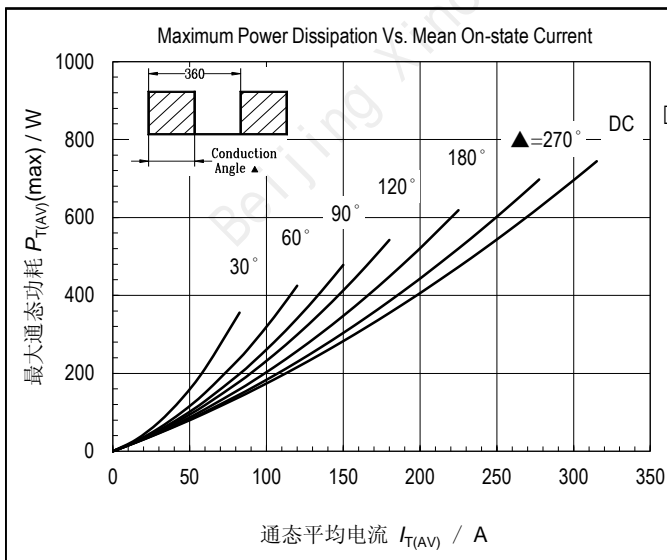

图7. 通态浪涌电流与周波数的关系曲线

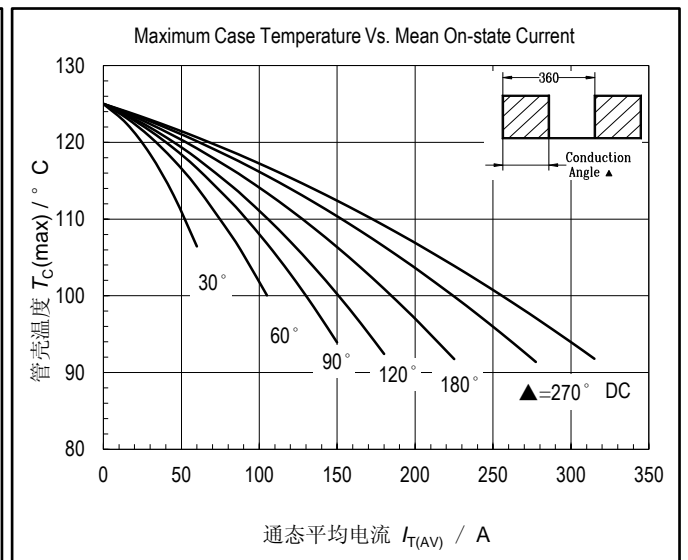

图8.  $I^2t$  特性曲线

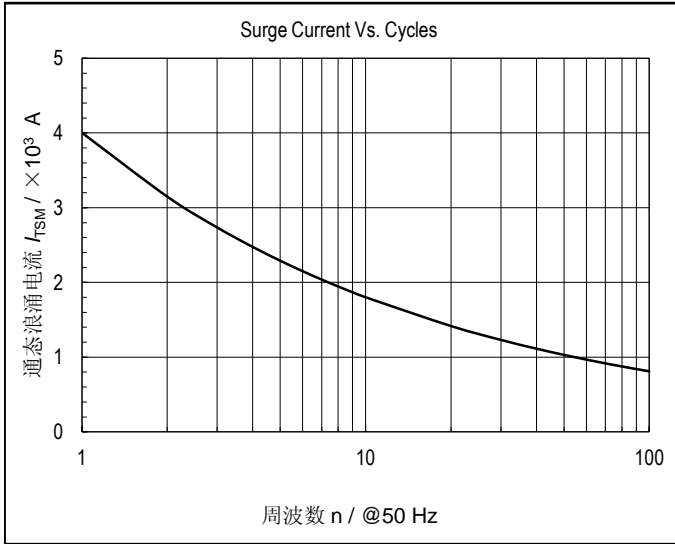

图9. 门极触发特性曲线

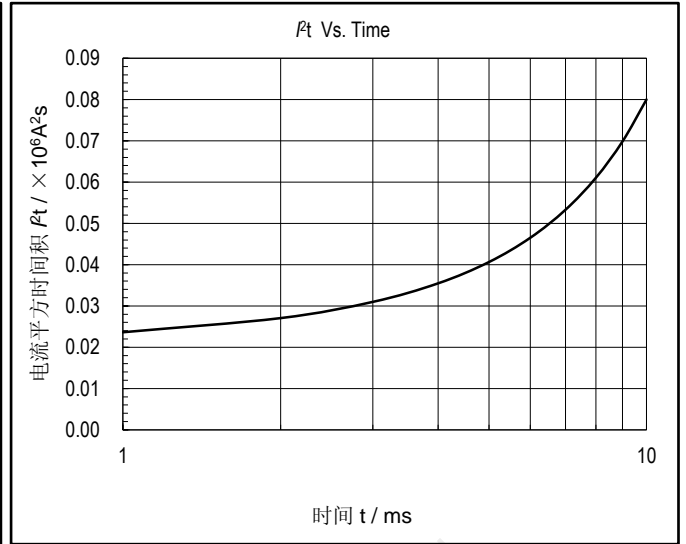

图10. 不同结温下的门极触发区

A为可靠触发区，  
B为不可靠触发区。  
C为建议采用的门极负载线。

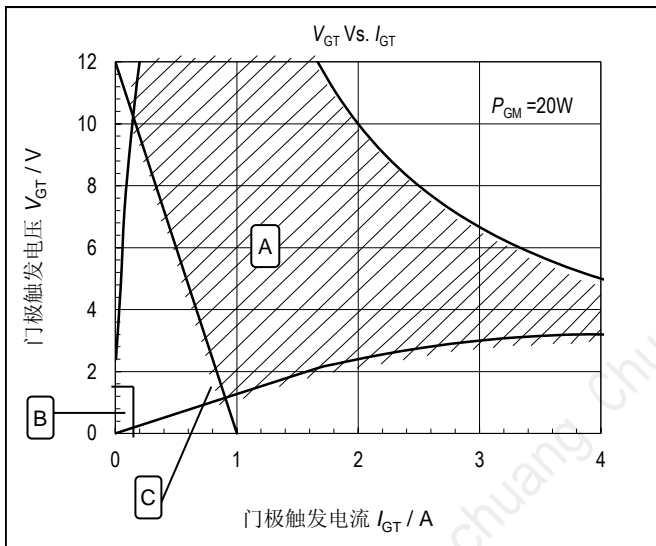
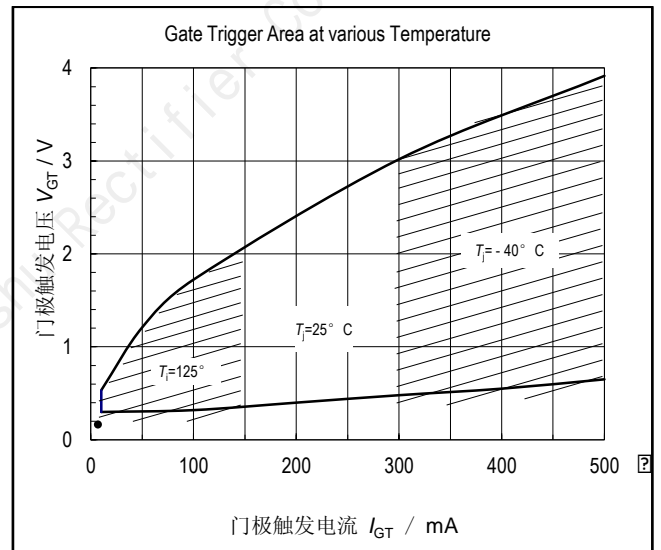
A is Recommended Triggering Area.  
B is Unreliable Triggering Area.  
C is Recommended Gate Load Line.