



High-end Power Semiconductor Manufacturer

ZP4800A 6900-8000V Standard Rectifier Diode

- High power cycling capability
- Low on-state and switching losses
- Optimized for line frequency rectifiers
- Designed for traction and industrial applications



Average forward current				I_{FAV}	4800 A			
Repetitive peak reverse voltage				V_{RRM}	6900 – 8000 V			
V_{RRM} , V	6900	7000	7200	7400	7600	7800	8000	
Voltage code	69	70	72	74	76	78	80	
T_{jr} , °C	-40 – 150							

MAXIMUM ALLOWABLE RATINGS

Symbols and parameters		Units	Values	Test conditions	
ON-STATE					
I_{FAV}	Average forward current	A	4800	$T_c=100\text{ °C}$; Double side cooled; 180° half-sine wave; 50 Hz	
I_{FRMS}	RMS forward current	A	7500	$T_c=100\text{ °C}$	
I_{FSM}	Surge forward current	kA	76.2	$T_j=T_{j\max}$	180° half-sine wave; ($t_p=10\text{ ms}$); $V_R=0\text{ V}$;
I^2t	Safety factor	$A^2s\cdot 10^4$	2903.2	$T_j=T_{j\max}$	180° half-sine wave; ($t_p=10\text{ ms}$)
BLOCKING					
V_{RRM}	Repetitive peak reverse voltages	V	6900-8000	$T_{j\min} < T_j < T_{j\max}$; 180° half-sine wave	
V_{RSM}	Non-repetitive peak reverse voltages	V	7400-8500	$T_j=25, 150\text{ °C}$; $I_{RRM} \leq 600\text{ mA}$; $V_R=V_{RRM}$; $t_p=10\text{ ms}$	
THERMAL					
T_{stg}	Storage temperature	°C	-40-150		
T_j	Operating junction temperature	°C	-40-150		
MECHANICAL					
F	Mounting force	kN	120.0		

CHARACTERISTICS

Symbols and parameters		Units	Values	Conditions
ON-STATE				
V_{FM}	Peak forward voltage, max	V	1.66	$T_j=150\text{ }^\circ\text{C}; I_{TM}=6000\text{ A}$
$V_{F(TO)}$	Forward threshold voltage, max	V	1.00	$T_j=T_{j\text{ max}}$
r_T	Forward slope resistance, max	m Ω	0.115	
BLOCKING				
I_{RRM}	Repetitive peak reverse current, max	mA	600	$T_j=T_{j\text{ max}};$ $V_R=V_{RRM}$
THERMAL				
R_{thjc}	Thermal resistance, junction to case, max	$^\circ\text{C/W}$	0.004	
R_{thck}	Thermal resistance, case to heatsink, max	$^\circ\text{C/W}$	0.001	
MECHANICAL				
w	Weight, typ	g	3600	

OVERALL DIMENSIONS

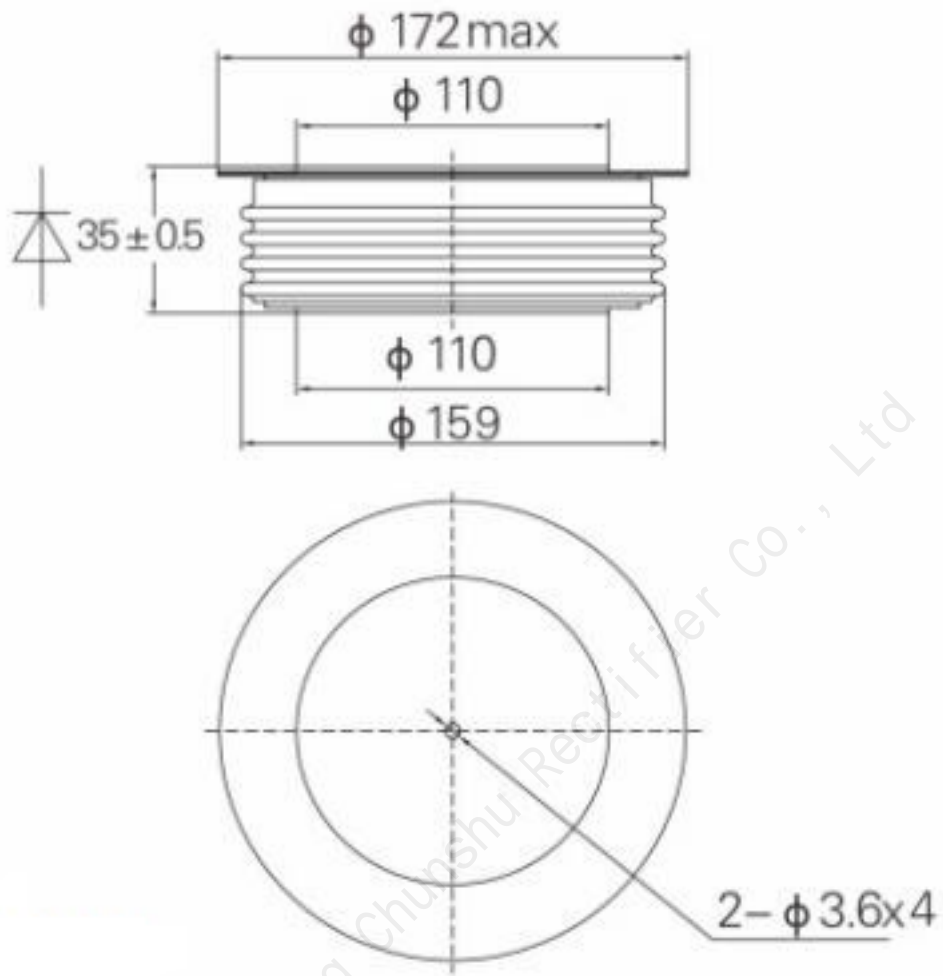

ZT130DT

All dimensions in millimeters



图1. 正向伏安特性曲线



图2. 瞬态热阻抗曲线

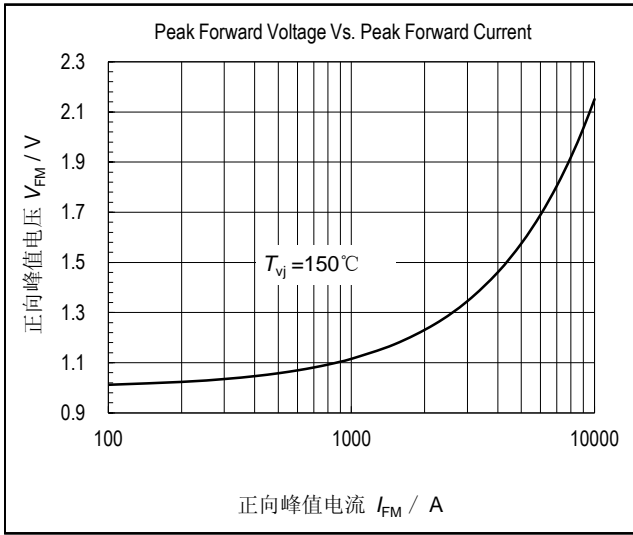

图3. 最大正向功耗与正向平均电流的关系曲线

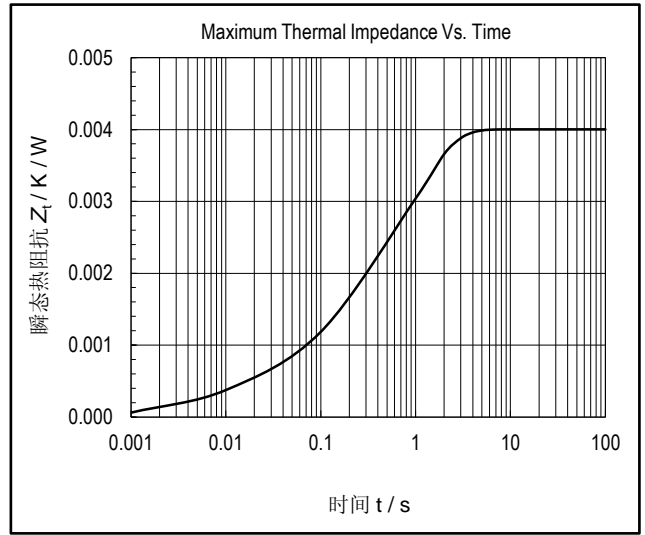

图4. 管壳温度与正向平均电流的关系曲线

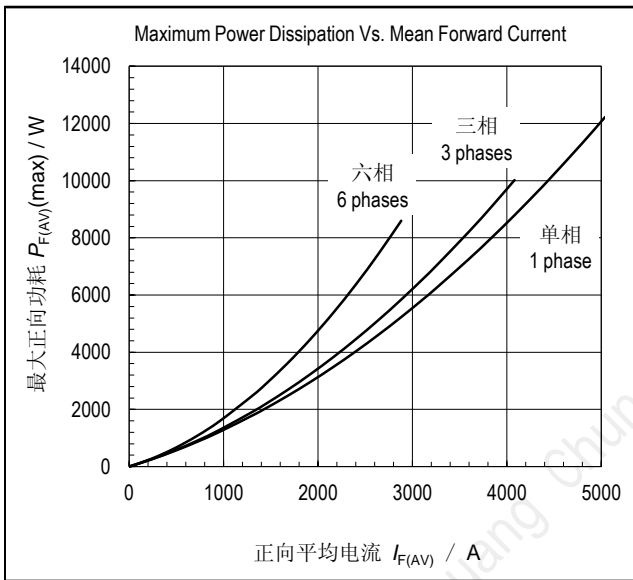

图5. 正向浪涌电流与周波数的关系曲线

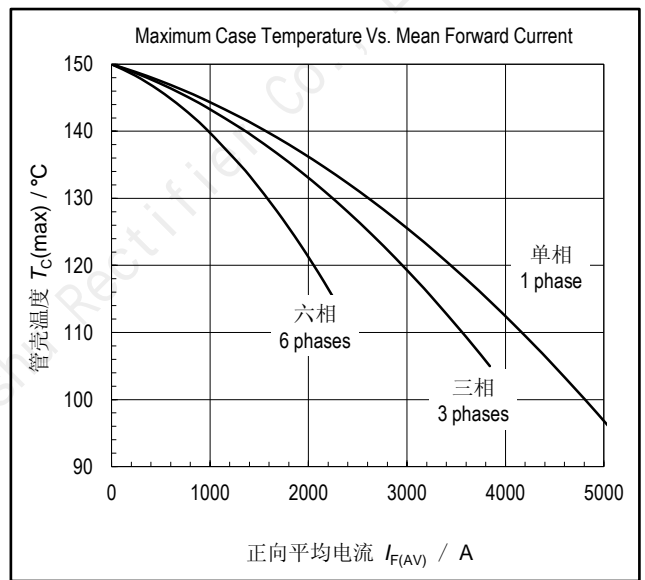
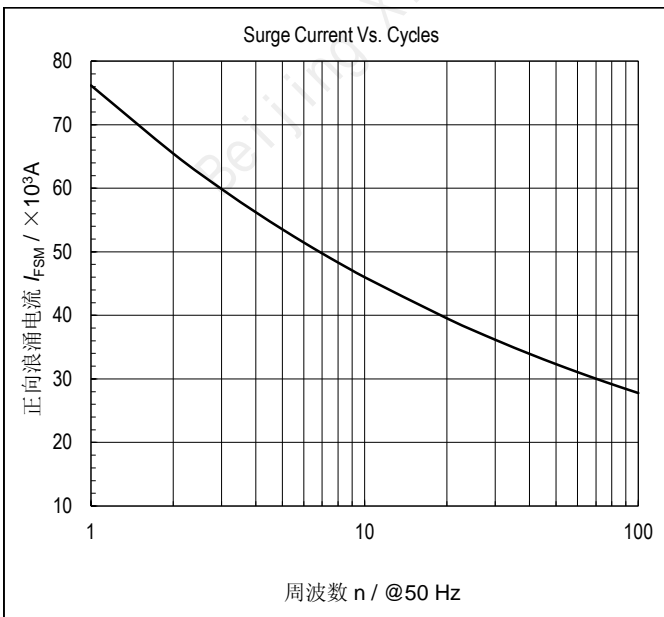
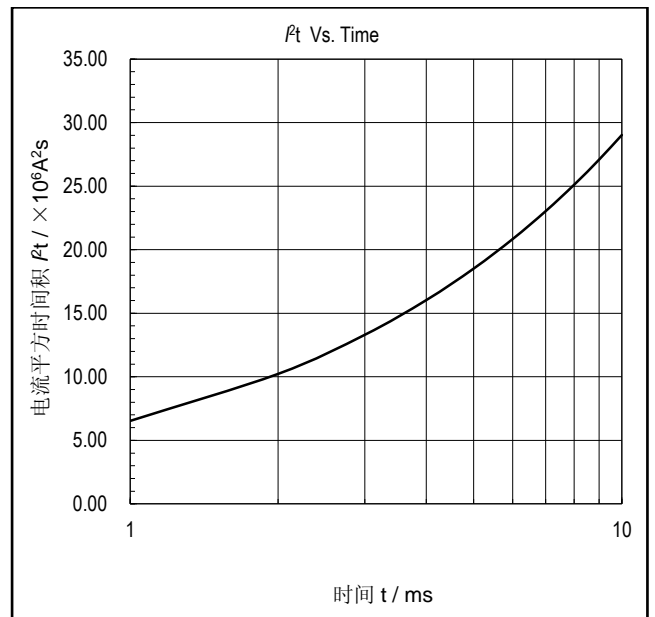

图6. I^2t 特性曲线