



高端电力电子器件和装置制造商

TL353-500

光控晶闸管

<ul style="list-style-type: none"> ◆ $V_{DRM} = 8000\text{ V}$ ◆ $V_{RRM} = 8000\text{ V}$ ◆ $I_{T(AV)} = 670\text{ A}$ ($T_C = 70\text{ }^\circ\text{C}$) ◆ $I_{T(AV)} = 540\text{ A}$ ($T_C = 85\text{ }^\circ\text{C}$) ◆ $I_{TSM} = 10.5\text{ kA}$ ($T_j = 120\text{ }^\circ\text{C}$) ◆ $P_{LM} = 40\text{ mW}$ 			
<ul style="list-style-type: none"> ◆ 光触发 ◆ 低通态和开关损耗 			
<p>最大额定数值</p>			
参数及测试条件	符号	数值	单位
Repetitive peak off-state voltage, $T_j = -40 \dots + 120\text{ }^\circ\text{C}$	V_{DRM}	8000	V
Repetitive peak reverse voltage, $T_j = -40 \dots + 120\text{ }^\circ\text{C}$	V_{RRM}	8000	
Non-repetitive peak off-state voltage, $T_j = -40 \dots + 120\text{ }^\circ\text{C}$	V_{DSM}	8100	
Non-repetitive peak reverse voltage, $T_j = -40 \dots + 120\text{ }^\circ\text{C}$	V_{RSM}	8100	
Repetitive peak off-state current/ Repetitive peak reverse current, $T_j = 120\text{ }^\circ\text{C}$, $V_D / V_R = V_{DRM} / V_{RRM}$	I_{DRM} / I_{RRM}	150	mA
Average on-state current, $f = 50\text{ Hz}$, double side cooling $T_C = 85\text{ }^\circ\text{C}$ $T_C = 70\text{ }^\circ\text{C}$	$I_{T(AV)}$	540 670	A
RMS on-state current, $T_C = 85\text{ }^\circ\text{C}$, $f = 50\text{ Hz}$	I_{TRMS}	851	A
Surge non-repetitive on-state current, $T_j = 120\text{ }^\circ\text{C}$, $V_R = 0$, $t_p = 10\text{ ms}$	I_{TSM}	10.5	kA
Safety factor	I^2t	$5.5 \cdot 10^5$	A^2s
Critical rate of rise of on-state current, $T_j = 120\text{ }^\circ\text{C}$, $V_D = 0.67V_{DRM}$, $I_T = 1260\text{ A}$, $P_{LM} = 40\text{ mW}$, $t_L = 10\text{ }\mu\text{s}$, $f = 50\text{ Hz}$	$(di_T/dt)_{crit}$	300	$\text{A}/\mu\text{s}$
Critical rate of rise of off-state voltage, $T_j = 120\text{ }^\circ\text{C}$, $V_D = 0.67V_{DRM}$	$(dv_D/dt)_{crit}$	1000 - 2000	$\text{V}/\mu\text{s}$
Minimum gate trigger light power, $T_j = 25\text{ }^\circ\text{C}$, $V_D = 12\text{ V}$	P_{LM}	40	mW
Operation junction temperature range	T_j	$-40 \dots +120$	$^\circ\text{C}$
Storage temperature range	T_{stg}	$-40 \dots +50$	$^\circ\text{C}$

电学特性					
Parameter and conditions	Symbol	Values			Units
		min	typ.	max	
Peak on-state voltage, $T_j = 25\text{ }^\circ\text{C}$, $I_T = 1980\text{ A}$	V_{TM}	-	-	3.00	V
On-state threshold voltage, $T_j = 120\text{ }^\circ\text{C}$, $I_T = 1000 - 3000\text{ A}$	$V_{T(TO)}$	-	-	1.26	
On-state slope resistance, $T_j = 120\text{ }^\circ\text{C}$, $I_T = 1000 - 3000\text{ A}$	r_T	-	-	1.47	mΩ
Delay time, $T_j = 25\text{ }^\circ\text{C}$, $V_D = 1000\text{ V}$, $I_T = 630\text{ A}$, $P_{LM} = 40\text{ mW}$, $t_L = 10\text{ }\mu\text{s}$, $t_r = 0.5\text{ }\mu\text{s}$	t_d	-	-	5.0	μs
Turn off-time, $T_j = 120\text{ }^\circ\text{C}$, $I_T = 630\text{ A}$, $di_T/dt = -5\text{ A}/\mu\text{s}$, $V_R \geq 100\text{ V}$, $V_D = 0.67V_{DRM}$, $dv_D/dt = 20\text{ V}/\mu\text{s}$	t_q	-	900	-	
Reverse recovery charge, $T_j = 120\text{ }^\circ\text{C}$, $I_T = 630\text{ A}$, $di_T/dt = -5\text{ A}/\mu\text{s}$, $V_R \geq 100\text{ V}$	Q_{RR}	-	-	3500	μAs
Holding current, $T_j = 25\text{ }^\circ\text{C}$, $V_D = 12\text{ V}$	I_H	-	-	100	mA
Latching current, $T_j = 25\text{ }^\circ\text{C}$, $V_D = 12\text{ V}$, $P_{LM} = 40\text{ mW}$, $t_L = 10\text{ }\mu\text{s}$, $t_r = 0.5\text{ }\mu\text{s}$	I_L	-	-	1000	
热学特性					
Thermal junction to case resistance, sin 180°: double side cooled DC: double side cooled	$R_{th(j-c)}$ $R_{th(j-c)}$	-	-	0.0200 0.0190	°C/W
Thermal resistance case to heatsink, double side cooled single side cooled	$R_{th(c-h)}$	-	-	0.005 0.010	
力学特性					
Weight	w	-	0.65	-	kg
Clamping force	F	15	-	26	kN
Maximum acceleration (at nominal mounting force)	a	-	-	50	m/s ²
Minimal cathode-anode distance on insulator surface	D_s	-	28.8	-	mm
Air strike distance	D_a	-	22.5	-	mm

TL353-500--- 外形尺寸

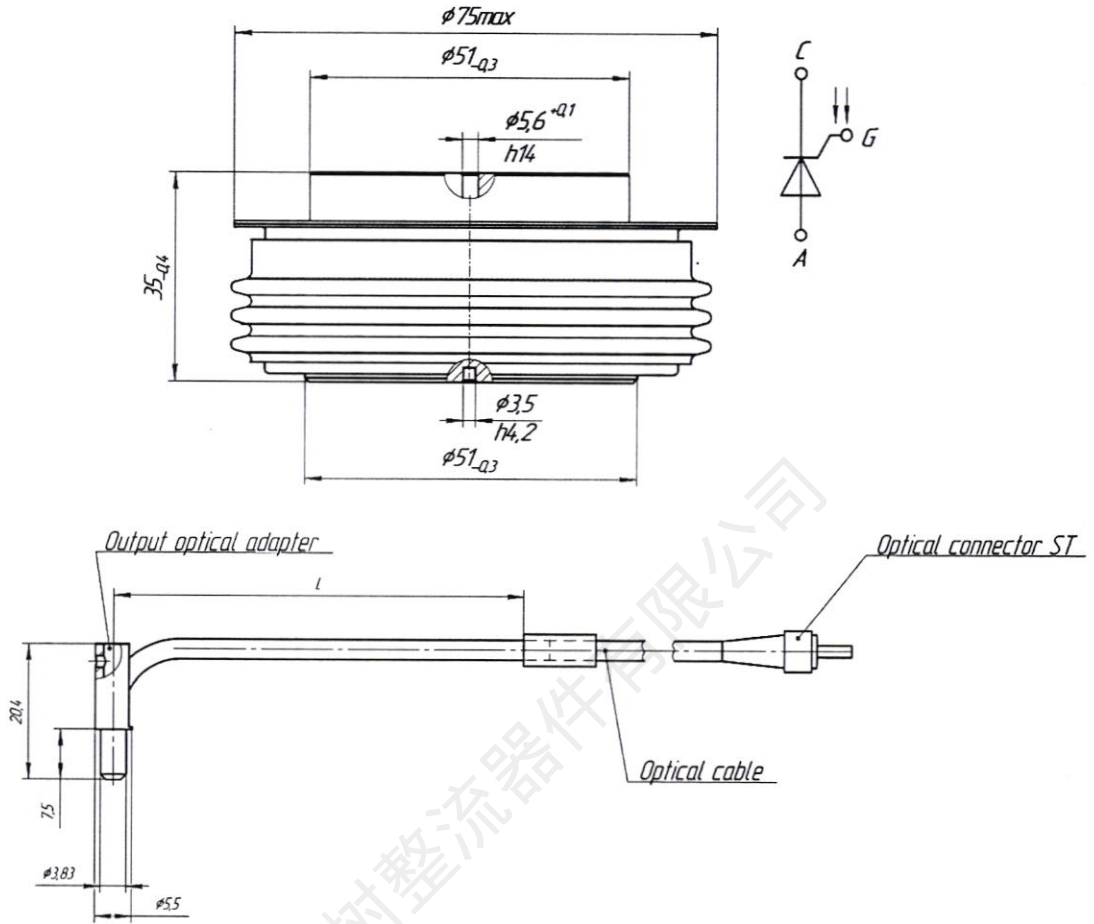

Designation	L,mm
Optical adapter OA57	57
Optical adapter OA65	65

C – Cathode, A – Anode, G – Gate

Device Outline Drawing
(dimensions in mm)