



High-end Power Semiconductor Manufacturer

KP1000A 2000V-2800V

Phase Control Thyristor

- High power cycling capability
- Low on-state and switching losses
- Designed for traction and industrial applications



Mean on-state current	I_{TAV}		1000 A		
Repetitive peak off-state voltage	V_{DRM}		2000 – 2800 V		
Repetitive peak reverse voltage	V_{RRM}				
Turn-off time	t_q		320 μ s		
V_{DRM}, V_{RRM}, V	2000	2200	2400	2600	2800
Voltage code	20	22	24	26	28
$T_{j}, ^\circ C$	-60 – 125				

MAXIMUM ALLOWABLE RATINGS

Symbols and parameters		Units	Values	Test conditions
ON-STATE				
I_{TAV}	Mean on-state current	A	1000	$T_c=85^\circ C$, Double side cooled 180° half-sine wave; 50 Hz
I_{TRMS}	RMS on-state current	A	1570	$T_c=85^\circ C$, Double side cooled 180° half-sine wave; 50 Hz
I_{TSM}	Surge on-state current	kA	20.0 23.0	$T_j=T_{j\ max}$ $T_j=25^\circ C$ 180° half-sine wave; 50 Hz ($t_p=10\ ms$); single pulse; $V_D=V_R=0\ V$; Gate pulse: $I_G=2\ A$; $t_{GP}=50\ \mu s$; $di_G/dt \geq 1\ A/\mu s$
			21.0 24.0	$T_j=T_{j\ max}$ $T_j=25^\circ C$ 180° half-sine wave; 60 Hz ($t_p=8.3\ ms$); single pulse; $V_D=V_R=0\ V$; Gate pulse: $I_G=2\ A$; $t_{GP}=50\ \mu s$; $di_G/dt \geq 1\ A/\mu s$
I^2t	Safety factor	$A^2s \cdot 10^3$	2000 2645	$T_j=T_{j\ max}$ $T_j=25^\circ C$ 180° half-sine wave; 50 Hz ($t_p=10\ ms$); single pulse; $V_D=V_R=0\ V$; Gate pulse: $I_G=2\ A$; $t_{GP}=50\ \mu s$; $di_G/dt \geq 1\ A/\mu s$
			1830 2390	$T_j=T_{j\ max}$ $T_j=25^\circ C$ 180° half-sine wave; 60 Hz ($t_p=8.3\ ms$); single pulse; $V_D=V_R=0\ V$; Gate pulse: $I_G=2\ A$; $t_{GP}=50\ \mu s$; $di_G/dt \geq 1\ A/\mu s$
BLOCKING				
V_{DRM}, V_{RRM}	Repetitive peak off-state and Repetitive peak reverse voltages	V	2000 – 2800	$T_{j\ min} < T_j < T_{j\ max}$; 180° half-sine wave; 50 Hz; Gate open
V_{DSM}, V_{RSM}	Non-repetitive peak off-state and Non-repetitive peak reverse voltages	V	2100 – 2900	$T_{j\ min} < T_j < T_{j\ max}$; 180° half-sine wave; 50 Hz; single pulse; Gate open
V_D, V_R	Direct off-state and Direct reverse voltages	V	$0.75 \cdot V_{DRM}$ $0.75 \cdot V_{RRM}$	$T_j=T_{j\ max}$; Gate open

TRIGGERING				
I_{FGM}	Peak forward gate current	A	8	$T_j = T_{j \max}$
V_{RGM}	Peak reverse gate voltage	V	5	
P_G	Gate power dissipation	W	4	$T_j = T_{j \max}$ for DC gate current
SWITCHING				
$(di_T/dt)_{crit}$	Critical rate of rise of on-state current non-repetitive (f=1 Hz)	A/ μ s	400	$T_j = T_{j \max}; V_D = 0.67 \cdot V_{DRM}; I_{TM} = 2 I_{TAV};$ Gate pulse: $I_G = 2$ A; $t_{GP} = 50 \mu$ s; $di_G/dt \geq 1$ A/ μ s
THERMAL				
T_{stg}	Storage temperature	$^{\circ}$ C	-60 – 125	
T_j	Operating junction temperature	$^{\circ}$ C	-60 – 125	
MECHANICAL				
F	Mounting force	kN	24.0 – 28.0	
a	Acceleration	m/s ²	50 100	Device unclamped Device clamped

CHARACTERISTICS

Symbols and parameters		Units	Values	Conditions	
ON-STATE					
V_{TM}	Peak on-state voltage, max	V	2.20	$T_j = 25 \text{ }^{\circ}\text{C}; I_{TM} = 3140$ A	
$V_{T(TO)}$	On-state threshold voltage, max	V	1.15	$T_j = T_{j \max};$	
r_T	On-state slope resistance, max	m Ω	0.390	$0.5 \pi I_{TAV} < I_T < 1.5 \pi I_{TAV}$	
I_L	Latching current, max	mA	1500	$T_j = 25 \text{ }^{\circ}\text{C}; V_D = 12$ V; Gate pulse: $I_G = 2$ A; $t_{GP} = 50 \mu$ s; $di_G/dt \geq 1$ A/ μ s	
I_H	Holding current, max	mA	300	$T_j = 25 \text{ }^{\circ}\text{C};$ $V_D = 12$ V; Gate open	
BLOCKING					
I_{DRM}, I_{RRM}	Repetitive peak off-state and Repetitive peak reverse currents, max	mA	150	$T_j = T_{j \max};$ $V_D = V_{DRM}; V_R = V_{RRM}$	
$(dv_D/dt)_{crit}$	Critical rate of rise of off-state voltage ¹⁾ , min	V/ μ s	1000	$T_j = T_{j \max};$ $V_D = 0.67 \cdot V_{DRM};$ Gate open	
TRIGGERING					
V_{GT}	Gate trigger direct voltage, max	V	3.00 2.00	$T_j = 25 \text{ }^{\circ}\text{C}$ $T_j = T_{j \max}$	$V_D = 12$ V; $I_D = 3$ A; Direct gate current
I_{GT}	Gate trigger direct current, max	mA	300 200	$T_j = 25 \text{ }^{\circ}\text{C}$ $T_j = T_{j \max}$	
V_{GD}	Gate non-trigger direct voltage, min	V	0.25	$T_j = T_{j \max};$ $V_D = 0.67 \cdot V_{DRM};$	
I_{GD}	Gate non-trigger direct current, min	mA	10.00	Direct gate current	
SWITCHING					
t_{gd}	Delay time	μ s	2.50	$T_j = 25 \text{ }^{\circ}\text{C}; V_D = 0.4 \cdot V_{DRM}; I_{TM} = I_{TAV};$ Gate pulse: $I_G = 2$ A; $t_{GP} = 50 \mu$ s; $di_G/dt \geq 1$ A/ μ s	
t_q	Turn-off time ²⁾ , max	μ s	320	$dv_D/dt = 50$ V/ μ s; $T_j = T_{j \max}; I_{TM} = I_{TAV};$ $di_R/dt = -10$ A/ μ s; $V_R = 100$ V; $V_D = 0.67 \cdot V_{DRM}$	

THERMAL					
R_{thjc}	Thermal resistance, junction to case, max	°C/W	0.0180	Direct current	Double side cooled
R_{thjc-A}			0.0396		Anode side cooled
R_{thjc-K}			0.0324		Cathode side cooled
R_{thck}	Thermal resistance, case to heatsink, max	°C/W	0.0040	Direct current	
MECHANICAL					
w	Weight, typ	g	510		
D_s	Surface creepage distance	mm (inch)	30.38 (1.196)		
D_a	Air strike distance	mm (inch)	18.05 (0.710)		

Beijing Xinchuang Chunshu Rectifier Co., Ltd

OVERALL DIMENSIONS

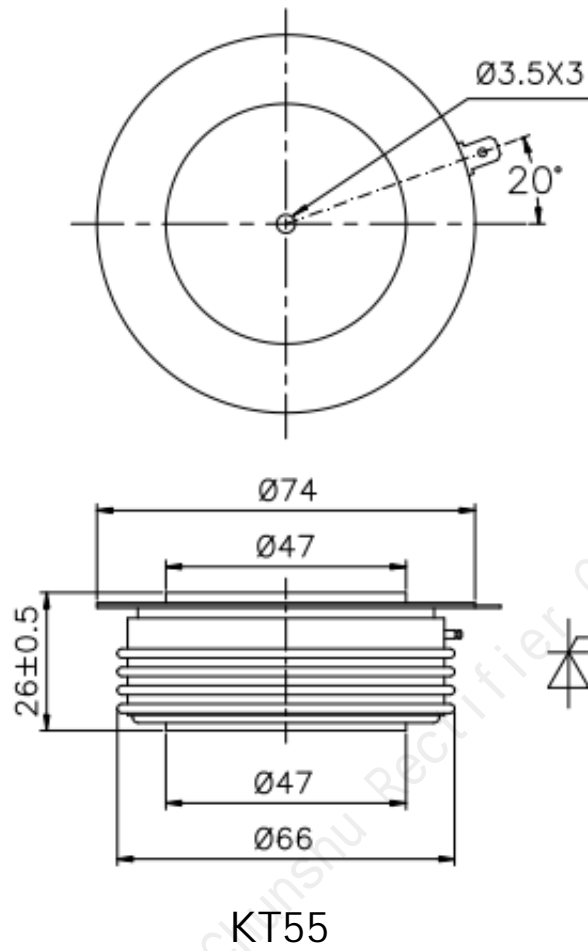

All dimensions in millimeters