



High-end Power Semiconductor Manufacturer

KP1000A 4600V-5200V

Phase Control Thyristor

- High power cycling capability
- Low on-state and switching losses
- Designed for traction and industrial applications



Mean on-state current	I_{TAV}	1000 A		
Repetitive peak off-state voltage	V_{DRM}	4600 – 5200 V		
Repetitive peak reverse voltage	V_{RRM}			
Turn-off time	t_q	800 μ s		
V_{DRM}, V_{RRM}, V	4600	4800	5000	5200
Voltage code	46	48	50	52
$T_j, ^\circ\text{C}$	– 60 – 125			

MAXIMUM ALLOWABLE RATINGS

Symbols and parameters		Units	Values	Test conditions
ON-STATE				
I_{TAV}	Mean on-state current	A	1000	$T_c = 85^\circ\text{C}$, Double side cooled 180° half-sine wave; 50 Hz
I_{TRMS}	RMS on-state current	A	1570	$T_c = 85^\circ\text{C}$, Double side cooled 180° half-sine wave; 50 Hz
I_{TSM}	Surge on-state current	kA	26.0 30.0	$T_j = T_{j\max}$ $T_j = 25^\circ\text{C}$ 180° half-sine wave; 50 Hz ($t_p = 10$ ms); single pulse; $V_D = V_R = 0$ V; Gate pulse: $I_G = 2$ A; $t_{GP} = 50$ μ s; $di_G/dt \geq 1$ A/ μ s
			28.0 32.0	$T_j = T_{j\max}$ $T_j = 25^\circ\text{C}$ 180° half-sine wave; 60 Hz ($t_p = 8.3$ ms); single pulse; $V_D = V_R = 0$ V; Gate pulse: $I_G = 2$ A; $t_{GP} = 50$ μ s; $di_G/dt \geq 1$ A/ μ s
I^2t	Safety factor	$A^2s \cdot 10^3$	3380 4500	$T_j = T_{j\max}$ $T_j = 25^\circ\text{C}$ 180° half-sine wave; 50 Hz ($t_p = 10$ ms); single pulse; $V_D = V_R = 0$ V; Gate pulse: $I_G = 2$ A; $t_{GP} = 50$ μ s; $di_G/dt \geq 1$ A/ μ s
			3250 4245	$T_j = T_{j\max}$ $T_j = 25^\circ\text{C}$ 180° half-sine wave; 60 Hz ($t_p = 8.3$ ms); single pulse; $V_D = V_R = 0$ V; Gate pulse: $I_G = 2$ A; $t_{GP} = 50$ μ s; $di_G/dt \geq 1$ A/ μ s
BLOCKING				
V_{DRM}, V_{RRM}	Repetitive peak off-state and Repetitive peak reverse voltages	V	4600–5200	$T_{j\min} < T_j < T_{j\max}$; 180° half-sine wave; 50 Hz; Gate open
V_{DSM}, V_{RSM}	Non-repetitive peak off-state and Non-repetitive peak reverse voltages	V	4700–5300	$T_{j\min} < T_j < T_{j\max}$; 180° half-sine wave; 50 Hz; single pulse; Gate open
V_D, V_R	Direct off-state and Direct reverse voltages	V	0.75· V_{DRM} 0.75· V_{RRM}	$T_j = T_{j\max}$; Gate open

TRIGGERING				
I_{FGM}	Peak forward gate current	A	8	$T_j = T_{j\ max}$
V_{RGM}	Peak reverse gate voltage	V	5	
P_G	Gate power dissipation	W	5	$T_j = T_{j\ max}$ for DC gate current
SWITCHING				
$(di_T/dt)_{crit}$	Critical rate of rise of on-state current non-repetitive (f=1 Hz)	A/ μ s	630	$T_j = T_{j\ max}; V_D = 0.67 \cdot V_{DRM}; I_{TM} = 2 I_{TAV};$ Gate pulse: $I_G = 2\ A;$ $t_{GP} = 50\ \mu s; di_G/dt \geq 1\ A/\mu s$
THERMAL				
T_{stg}	Storage temperature	$^{\circ}C$	-60 – 125	
T_j	Operating junction temperature	$^{\circ}C$	-60 – 125	
MECHANICAL				
F	Mounting force	kN	33.0 – 40.0	
a	Acceleration	m/s^2	50 100	Device unclamped Device clamped

CHARACTERISTICS

Symbols and parameters		Units	Values	Conditions	
ON-STATE					
V_{TM}	Peak on-state voltage, max	V	2.90	$T_j = 25\ ^{\circ}C; I_{TM} = 5000\ A$	
$V_{T(TO)}$	On-state threshold voltage, max	V	1.00	$T_j = T_{j\ max};$	
r_T	On-state slope resistance, max	m Ω	0.510	$0.5\ \pi\ I_{TAV} < I_T < 1.5\ \pi\ I_{TAV}$	
I_L	Latching current, max	mA	1500	$T_j = 25\ ^{\circ}C; V_D = 12\ V;$ Gate pulse: $I_G = 2\ A;$ $t_{GP} = 50\ \mu s; di_G/dt \geq 1\ A/\mu s$	
I_H	Holding current, max	mA	300	$T_j = 25\ ^{\circ}C;$ $V_D = 12\ V; \text{Gate open}$	
BLOCKING					
I_{DRM}, I_{RRM}	Repetitive peak off-state and Repetitive peak reverse currents, max	mA	200	$T_j = T_{j\ max};$ $V_D = V_{DRM}; V_R = V_{RRM}$	
$(dv_D/dt)_{crit}$	Critical rate of rise of off-state voltage ¹⁾ , min	V/ μ s	1000	$T_j = T_{j\ max};$ $V_D = 0.67 \cdot V_{DRM}; \text{Gate open}$	
TRIGGERING					
V_{GT}	Gate trigger direct voltage, max	V	3.00 2.00	$T_j = 25\ ^{\circ}C$ $T_j = T_{j\ max}$	$V_D = 12\ V; I_D = 3\ A;$ Direct gate current
I_{GT}	Gate trigger direct current, max	mA	300 200	$T_j = 25\ ^{\circ}C$ $T_j = T_{j\ max}$	
V_{GD}	Gate non-trigger direct voltage, min	V	0.35	$T_j = T_{j\ max};$ $V_D = 0.67 \cdot V_{DRM};$	
I_{GD}	Gate non-trigger direct current, min	mA	15.00	Direct gate current	
SWITCHING					
t_{gd}	Delay time	μ s	4.00	$T_j = 25\ ^{\circ}C; V_D = 0.4 \cdot V_{DRM}; I_{TM} = I_{TAV};$ Gate pulse: $I_G = 2\ A;$ $t_{GP} = 50\ \mu s; di_G/dt \geq 1\ A/\mu s$	
t_q	Turn-off time ²⁾ , max	μ s	800	$dv_D/dt = 50\ V/\mu s; T_j = T_{j\ max}; I_{TM} = 2000\ A;$ $di_R/dt = -10\ A/\mu s; V_R = 100\ V;$ $V_D = 0.67\ V_{DRM};$	

THERMAL					
R_{thjc}	Thermal resistance, junction to case, max	°C/W	0.0100	Direct current	Double side cooled
R_{thjc-A}			0.0220		Anode side cooled
R_{thjc-K}			0.0180		Cathode side cooled
R_{thck}	Thermal resistance, case to heatsink, max	°C/W	0.0030	Direct current	
MECHANICAL					
w	Weight, typ	g	1000		
D_s	Surface creepage distance	mm (inch)	36.50 (1.437)		
D_a	Air strike distance	mm (inch)	16.5 (0.650)		

Beijing Xinchuang Chunshu Rectifier Co., Ltd

OVERALL DIMENSIONS

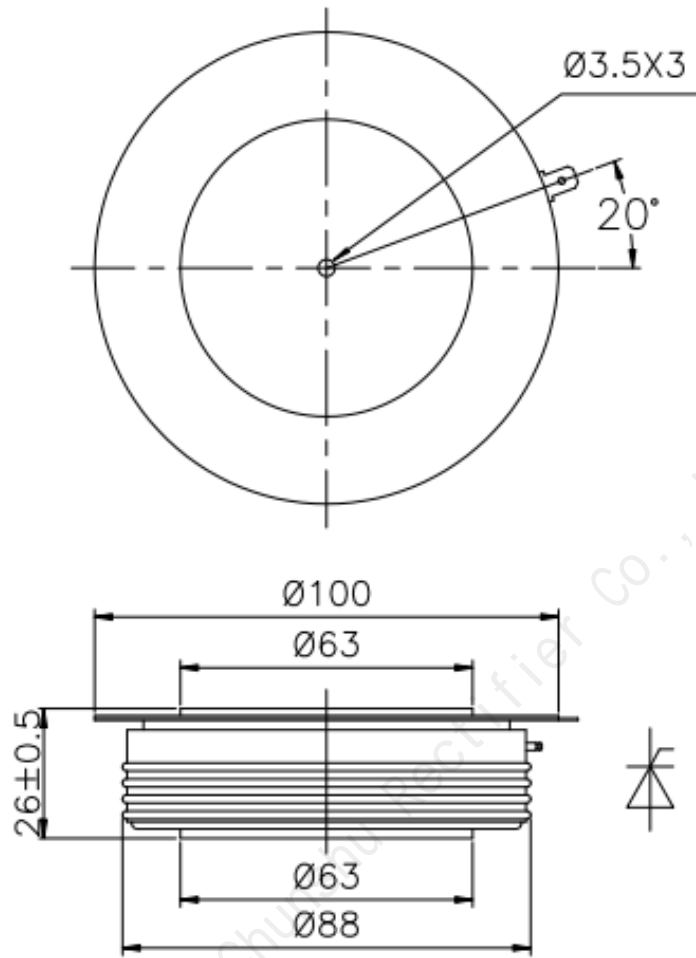

KT70

All dimensions in millimeters